

A

A

B

B

C

C

D

D

Capteur de temp/humidité

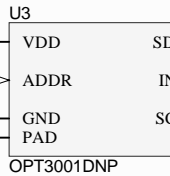
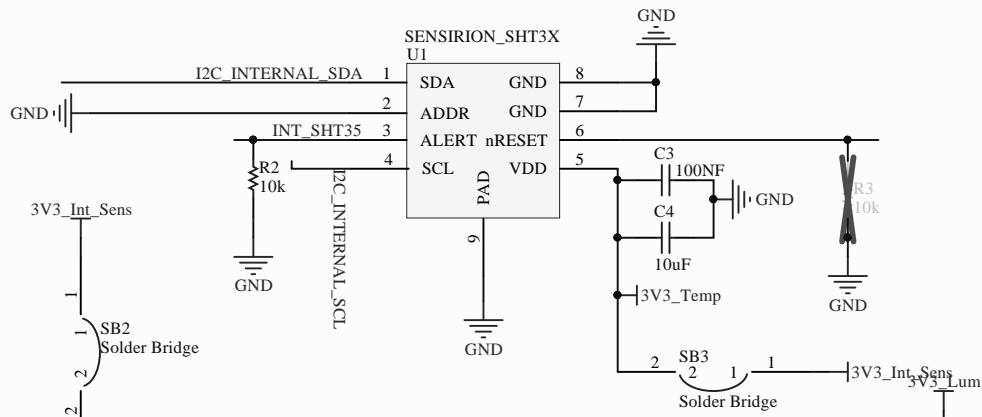

Capteur de luminosité

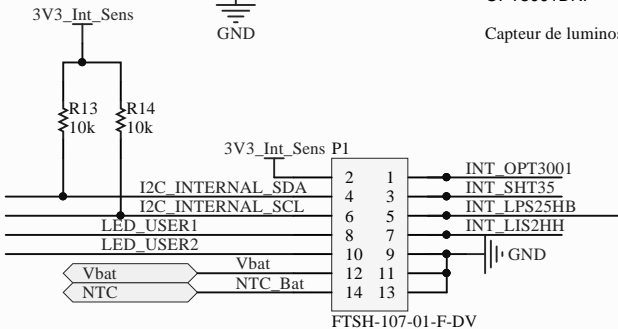

Connecteur Batterie

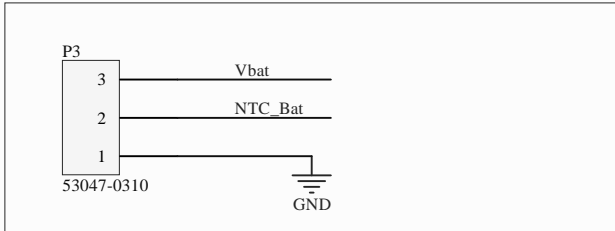

Gestion LED Etats

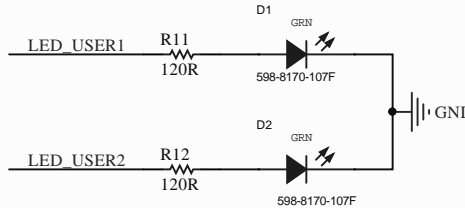

Title		
Size	Number	Revision
A4		
Date:	13/04/2018	Sheet of
File:	F:\Design Electronique\...\Capteurs.SchDoc	Drawn By:

Component list

Bill of Materials For Variant [Serie] of Schematic Document [Capteurs.SchDoc]

Source Data From:

Project:

Variant:

Capteurs.SchDoc

Capteur_Interne.PrjPcb

Serie



Report Date: 13/04/2018 09:47:21
 Print Date: 13-Apr-18 9:47:26 AM

#	Category	Designator	Description	Value	Tolerance	Voltage	Quantity	Manufacturer	Manufacturer Part Number	Distributor	istributor Part Num	Footprint
1	Capacitor	C1, C3, C6, C7	CAP CER 100NF 50V 20% Y5V 0603	100NF	20%	50V	4	AVX	MC0603F104Z500CT	Farnell	1759123	C0603
2	Capacitor	C2, C4, C5, C8	CAP CER 10UF 10V 10% X5R 0603	10uF	10%	10V	4	AVX	GRM188R61A106KE69D	RS	846-7293	C0603
3	Optoelectronics	D1, D2	LED GREEN CLEAR 0603 SMD, LED GREEN CLEAR 0805 SMD				2	KINGBRIGHT	KP-1608SGC	Farnell	8529833	LED_0603
4	Connector	P1	Embase 7X2 pitch 1.27				1	Samtec	FTSH-107-01-F-DV	Farnell	2308439	FTSH-107-01-XXX-DV-K
5	Connector	P3	Embase batterie 1.25mm 1A				1	JST	B3B-XH-A(LF)(SN)	Farnell	1516277	22-03-5035
6	Resistors	R2, R4, R7, R10, R13, R14	RES 10K 0.1W 1P 0603	10k	1%	75V	6	Multicomp	MCSR06X1002FTL	Farnell	2074167	R0603
7	Resistors	R11, R12	RES 120R 0.063W 1P 0603	120R	1%	50V	2	Multicomp	MCMR06X1200FTL	Farnell	2073369	R0603
8		SB1, SB2, SB3, SB4					4					Solder bridge
9	CI	U1	SHT3x Capteur d'humidité et de température				1	Sensirion AG	SHT35-DIS-B+SF2	Digikey	1649-1062-1-ND+1649-1001-ND	SENSIRION SHT3x DFN-8 /w CAP
10	CI	U2	Barometre/thermometre				1	ST	LPS25HBTR	RS	110-6550	HLGA-10L
11	CI	U3	Ambient Light Sensor, DNP0006A				1	Texas Instruments	OPT3001DNPT	RS	900-9810	DNP0006A
12	CI	U4	MEMS motion sensor: 3-axis ± 2g/± 8g smart digital output nano accelerometer, -40 to +85°C, LGA-16 (3x3x1), Tape and Reel				1	STMicroelectronics	LIS3DHTR	RS	793-1364	LGA16-3X3X1_N

Approved

Notes

28

